

Other CruzPro Products

- Depthsounders & Speed/Temperature/Log
 - AC & DC Volts/Amps/Amp-Hour/Freq/kW Monitor
 - LPG/Petrol Gas Detectors/Alarms
 - Digital Fuel Gauge & Fuel Consumption Calculator
 - Bilge Water Alarms & Bilge Pump Controllers
 - Windlass Controller/Chain Counter
 - Remote NMEA 0183 Digital Data Repeater
 - Smart and Manual Alternator Regulators
 - Marine Security System
 - RPM/Engine Hours/Elapsed Time Gauge
 - Digital Oil Pressure & Water Temperature Gauges/Alarm
 - Digital Tank Level Gauge/Alarms for Three Tanks
 - One and Three Bank Digital Volts Gauges
 - Digital Amps Gauge
 - Digital Clock/Watch/Race Timers/Alarms
 - 8 and 16 Amp Light Dimmers / Motor Speed Controller
 - Solar Panel Charge Controllers
 - 4 & 8 Channel NMEA Combiners/RS-232 Convertors
 - Engine/Exhaust Temp. Monitor & Digital Pyrometer
 - Remote NMEA 0183 Data Repeater/w 4 Input Channels
- www.cruzpro.com** Email to: **info@cruzpro.com**

CruzPro®
OP60



Oil Pressure Gauge/Alarm

Page 1

Selecting NMEA 0183 or External Alarm Output

The OP60 comes factory preset to use screw terminal pin (C) as an External Alarm output. If you would rather have NMEA 0183 serial data output on screw terminal (C), you can do so as follows:

While viewing Oil Pressure, press and hold down both the ▼ and ▲ keys for 10 seconds (until you hear a long beep). This operation switches the output mode between NMEA 1083 and External Alarm. The new output mode is automatically saved to memory.

When the external alarm output is activated, a 5V signal (10 mA Max.) is output on screw terminal (C).

Page 14

Introduction

The OP60 Oil Pressure Gauge displays engine oil pressure in Psi or Bars. It has built-in calibration curves for most popular pressure senders manufactured by VDO, Teleflex, and others (sender not provided). The sender type is easily selected with the front panel keys. Low and High pressure alarms can be set over the entire range of the instrument/sender. When activated, the OP60 built-in 85 dB alarm will sound and the display will flash. The alarms can be enabled or disabled with a single key press. Five levels of backlighting can be selected and all setup, calibrations constants, alarm values, and sender type are saved to nonvolatile memory. Data is output on an NMEA 0183 compatible serial data output or you can select to use the output line as an External Alarm Output.

Page 3

Table of Contents

Introduction	3
Specifications	4
Installation	5
Mounting and Wiring.	6
Operation	8
Key Functions	8
Backlight Intensity	8
Turning Alarms On/Off	9
Setting Low Pressure Alarm	10
Setting High Pressure Alarm	11
Selecting Sender Type	12
Selecting Psi or Bars Display	13
Calibrating the Instrument	13
Selecting NMEA 0183 or External Alarm Output	14
Notes and Warnings	15

Other CruzPro Products 16
©2000 CruzPro Ltd. OP60MAN-J
<http://www.cruzpro.com> Made in New Zealand

Notes and Warnings

- a) When setting calibration functions that require you to hold down a key while applying power to the OP60 - be sure to turn OFF the power first, then hold the key(s) down during and for at least 3 seconds AFTER the power has been applied to insure the computer has read the keys.
- b) If the pressure is below the minimum pressure or above the maximum pressure where manufacturer's calibration data is available for that sender, the OP60 displays "LO" or "HI".

Specifications

Power supply: 9.5 to 33.0 VDC, .035 amps nom.
Operating temperature: 32 to 122 F (0 to 50 C)
Size: 2.5" dia X 4.1" deep (61mm x 104 mm)
Accuracy: Better than 1 %, front panel adjustable calibration
Senders: Built-in calibration curves for most 10/20 to 180/250 ohm pressure senders such as VDO, Teleflex, etc.
Alarms: Accurate High and Low Pressure alarms settable from 0 to 400 PSI (0 to 27.5 Bars).
Display: 4 digits, Psi or Bars, 5 levels of backlight.
Data output: NMEA 0183 output of Pressure, Alarm values, Calibration constants, Sender Type. The data output pin can be programmed as an External Alarm Output, if desired.

Selecting Psi or Bars Display

Press and hold the ▼ key for three seconds while applying power to the instrument. This toggles between Psi and Bars display.

Calibrating the Instrument

Press and hold the + key for 10 seconds to enter the Pressure Calibration mode. Press the ▲ and ▼ keys to adjust the display to read the correct pressure. Press the + key to save the calibration information. Calibration is usually not required if the correct sender type is selected.

Selecting Sender Type

Press and hold the ▲ key and apply power to the instrument. You will see the display as shown below. Press any key to change to U-2, U-3 etc. Select the sender type from the table below. Press the + key to save your selection.

U-1 : VDO Ver 2	U-6 : Stewart/Warner
U-2 : VDO Ver 9	U-7 :
U-3 : VDO 262A	U-8 :
U-4 : VDO 217A	U-9 :
U-5 : Teleflex	U-10:

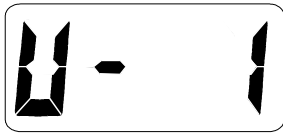

Installation

Before starting the installation, please read this entire section first. Be sure to install the bulkhead gasket before you install the instrument. Finger tighten the screws that mount the instrument bracket - do not use tools.

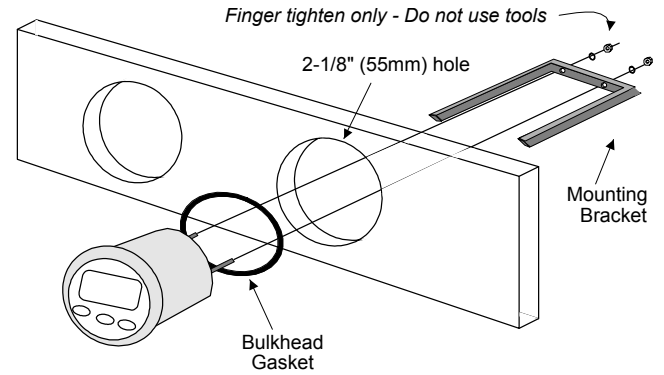

Figure 1

Setting Low Pressure Alarm

While viewing oil pressure, press and hold the ▼ key for ten (10) seconds. You will hear a long beep and see the display as shown. Press the ▲ and ▼ keys to set the desired low temperature alarm limit (0 to 400 Psi or 0 to 27.5 Bars). Press the + key to save your entry.



driver to make the connections to the screw terminal on the instrument case back as shown in figure 2.

- Carefully check all your wiring against those shown in figure 2. If everything is wired correctly you can mount the OP60 in the instrument hole. Be sure the bulkhead gasket is in place and use only finger tension to tighten the bracket hold-down nuts *Do not overtighten the bracket or you may damage the case - do not use tools to tighten the nuts.*

Mounting and Wiring

- Drill a 2-1/8" (55mm) mounting hole where you desire to mount the instrument (Figure 1).
- Bring the sender wires, ground, and power lines out of the mounting hole and use a small flat screw-

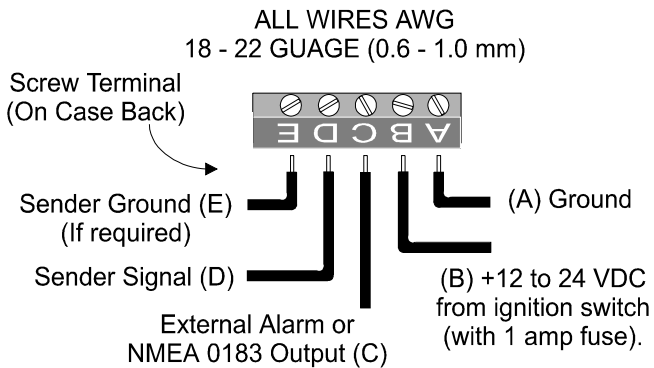

Page 6

Figure 2

Setting High Pressure Alarm

While viewing oil pressure, press and hold the ▲ key for ten (10) seconds. You will hear a long beep and see the display as shown. Press the ▲ and ▼ keys to set the desired high temperature alarm limit (0 to 400 Psi or 0 to 27.5 Bars). Press the + key to save your entry.



Page 11

Operation

Key Functions

The ▼, +, ▲ keys are used to select backlight levels, units of measure (Psi or Bars), pressure sender type, calibrate the instrument, set low and high pressure alarms and activate/deactivate the alarms. After changes are made, the new information is automatically saved to memory.

Backlight Intensity

Press the + key for 1/2 second to adjust the backlight level for nighttime viewing. Each time the level will get brighter 1, 2, 3, 4, OFF, 1, 2, ... etc.

Page 8

Turning Alarms ON/Off

Press the ▲ or ▼ key for 1/2 second to "arm" or "disarm" the alarms. When the alarms are armed a flag is displayed in the lower left corner as shown in figure 3.



Page 9